

# AFSHW DRIP HEADWORKS

## APPLICATIONS

AFS Headworks are an integral component when used in conjunction with Geoflow subsurface drip disposal tubing, whether it is used for septic tank effluent or pre-treated effluent. The AFS headworks contains the necessary components for screening the effluent, monitoring flow rates, control dosing and flushing functions of the drip field and monitoring pressure during dosing and flushing. The Headworks is housed in a watertight AFS Pump Basin and all internal piping and external pipe penetrations are completed prior to shipment saving valuable time in the field and allowing for a clean, problem free installation.



## SPECIFICATIONS

Basin Material:	24" PVC KOR FLO™ Riser Pipe for ¾" Headworks or 30" PVC Perma-Loc™ for 1" Headworks
Base Material:	FRP encapsulated wood core epoxy bonded to riser pipe
Access Cover Material:	FRP encapsulated wood core with neoprene gasket and stainless steel fasteners with 2" insulation
Inlet And Outlet Piping:	SCH40 ¾" or 1"
Plumbing Material:	SCH40 and SCH80 PVC
Flow Rating:	¾" 4-11 GPM, 1" 7-28 GPM

## FEATURES

- ◆ Rain Bird 24VAC Solenoid Valves for field and filter flush
- ◆ 100 psi Liquid Filled Pressure Gauges
- ◆ SCH40 and SCH80 PVC pipe and fittings
- ◆ SCH40 PVC Clear pipe to monitor flow
- ◆ SCH40 PVC Unions at critical locations for ease of maintenance or repair
- ◆ 24" PVC KOR FLO™ Ribbed Riser Pipe
- ◆ Orenco Systems® Inc. molded fiberglass base and access cover with 2" insulation
- ◆ Stainless steel lid fasteners and wrench included
- ◆ 100 micron Geoflow Spin Filter
- ◆ Badger 25 Meter

## OPTIONS

- ◆ ¾" (4-11 GPM) or 1" (7-28 GPM) Piping
- ◆ 30" PVC Perma-Loc™ Ribbed Riser Pipe

## MODEL NUMBERS

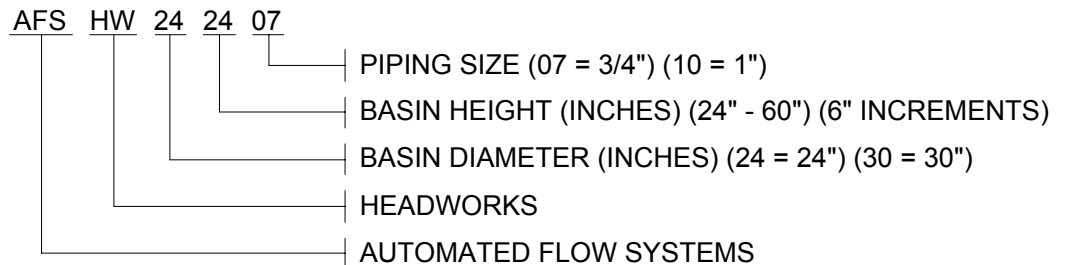
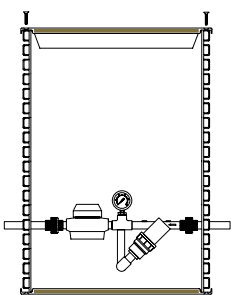

**BOISE, ID**  
208.585.9338  
208.585.9338 FAX

**COEUR D'ALENE, ID**  
888.809.6778  
208.664.2133  
208.667.8775 FAX

**SPOKANE, WA**  
800.359.9416  
509.534.5616  
509.535.6539 FAX

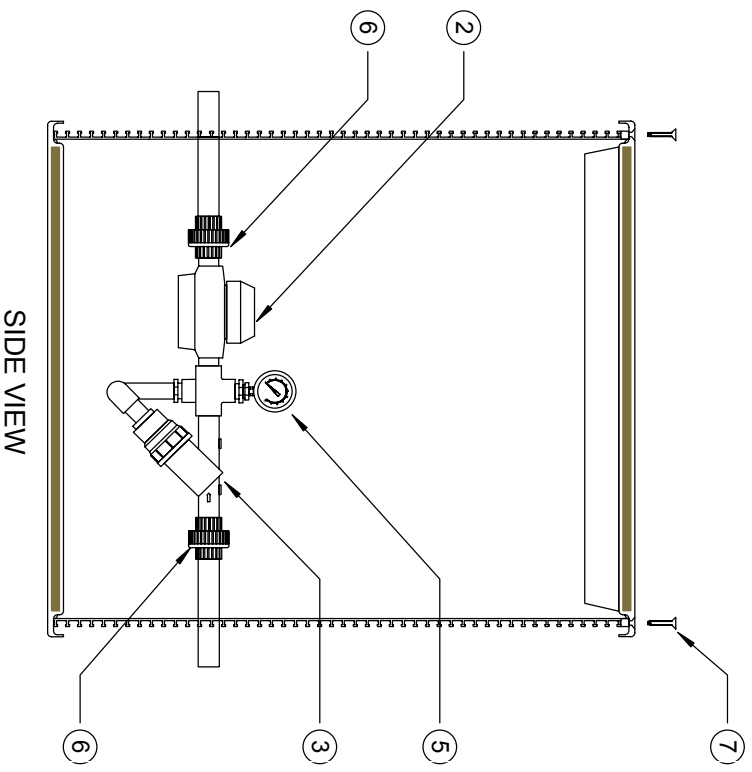
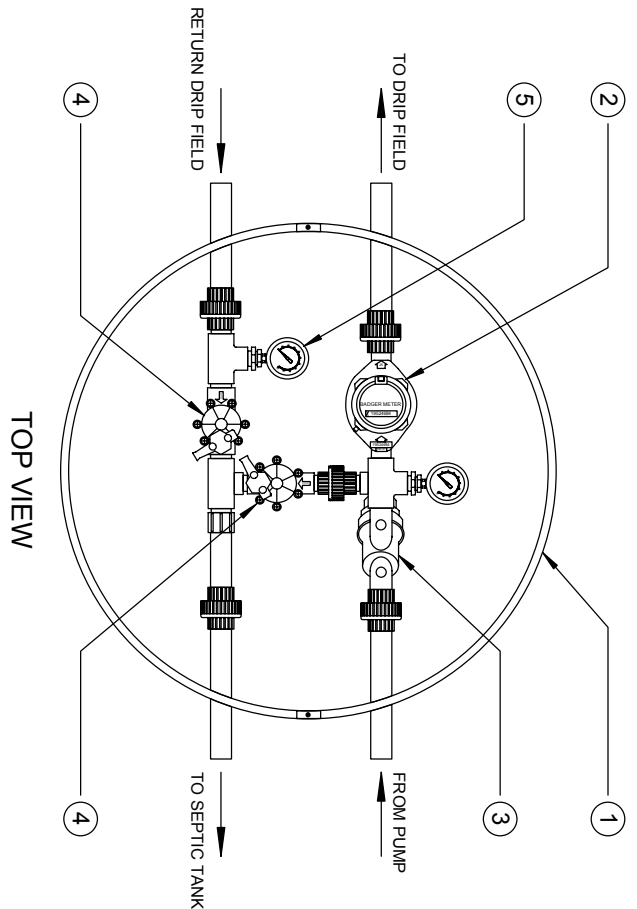

**GENERAL NOTES**

- ① PVC BASIN W/ 2" INSULATED FIBERGLASS LID
- ② BADGER MODEL 25 METER
- ③ GEOFLOW SPIN FILTER
- ④ FILTER FLUSH SOLENOID VALVE TT 24V
- ⑤ 0-100 PSI PRESSURE GAUGE S.S.
- ⑥ PVC UNION(S) FOR EASY REMOVAL
- ⑦ STAINLESS STEEL LID BOLTS

\*NOTE: PIPE AND FITTINGS IN SCH 40 PVC

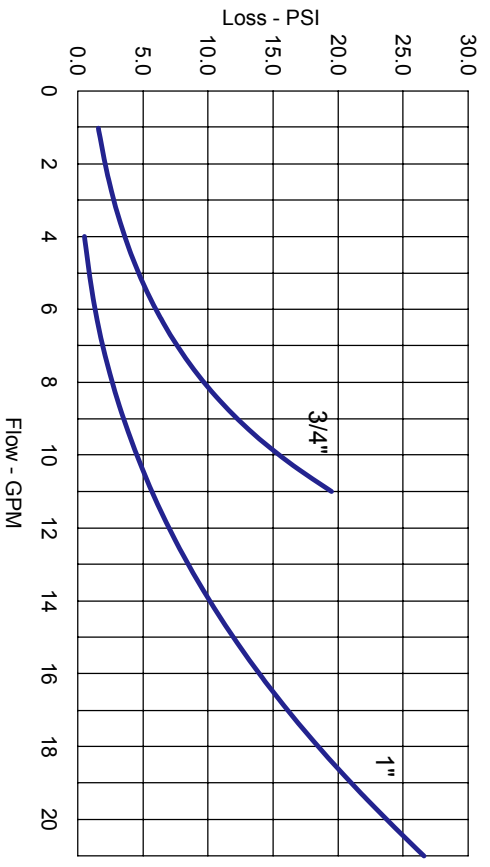

BOISE, ID 208-585-9338  
 COEUR D' ALENE, ID 888-809-6775 208-664-2133  
 SPOKANE, WA 800-359-9416 509-534-5616

DRAWN BY: **KCW**  
 SCALE: **NTS**  
 DATE: **06.20.05**  
 VERSION NO. **V1.0**

**AFSHW \_\_\_\_\_**  
**SUBSURFACE DRIP HEADWORKS**